

800G QSFP-DD to 4x200G QSFP112 Direct Attach Cable P/N: GQD-4QSP801-XXC

Features

- ✓ Hot-plug QSFP-DD form factor
- ✓ Support 8x 50/100Gb/s PAM4 modulation
- ✓ Commercial case temperature range of 0°C to 70°C
- ✓ 26 AWG ~30 AWG support up to 1.8m length
- ✓ Contain EEPROM & programmable to customized

Applications

- ✓ Data storage and communication industry
- ✓ Switch / router / HBA
- ✓ Enterprise network
- ✓ Data Center Network
- ✓ SAN

STANDARDS COMPLIANCE

- ✓ IEEE P802.3ck D3.0
- ✓ QSFP-DD MSA HW Rev 6.01
- ✓ QSFP112 MSA
- ✓ ROHS

Description

Gigalight's passive copper cable assembly series product provide superior signal integrity performance and reliability, QSFP-DD passive copper cable assembly doubles the number of 25G NRZ & 50G PAM4/lane from 4 to 8 lanes comparing QSFP cabling systems, double density still maintains backward plug compatibility to meet next generation market needs.

Gigalight's GQD-4QSP801-XXC cable assemblies are effective alternatives to fiber optics. The cable connects data signals from each of the 16 pairs on the single QSFP-DD end to the quad QSFP-DD ends, each pair operates at data rates of up to 100Gb/s, each QSFP-DD/QSFP112 port can be addressed by EEPROM to provide product information, which can be read or write by I2C interface.

Gigalight's GQD-4QSP801-XXC cable assemblies is compliant with the QSFP-DD-MSA and IEEE802.3ck ,it's high performance & cost effective I/O solutions for LAN, HPC and SAN. The high speed cable assemblies meet and exceed 800Gigabit Ethernet, InfiniBand EDR /HDR and temperature requirements for performance and reliability.



Absolute Maximum Ratings

Parameter	Symbol	Min	Max	Unit
Storage Temperature	T_s	-20	85	°C
Case Operating Temperature	T_c	0	70	°C
Humidity (non-condensing)	Rh	5	95	%

Recommended Operating Conditions

Parameter	Symbol	Min	Typical	Max	Unit
Operating Case Temperature	T_c	0		70	°C
Baud Rate per Lane (PAM4)	fd		53.125		GBaud/s
Humidity	Rh	5		85	%

Mechanical Dimensions

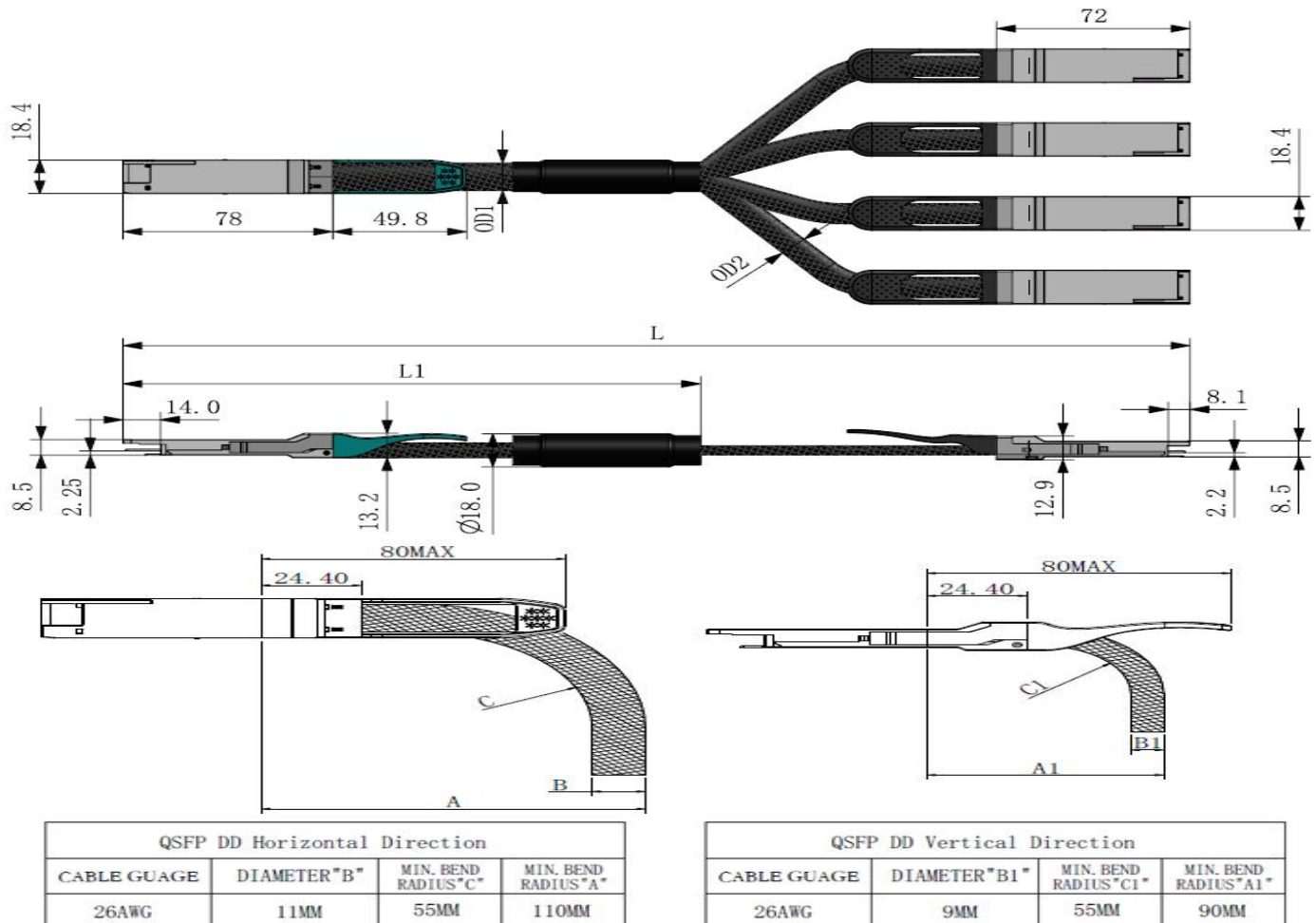

OSFP Electrical pinout

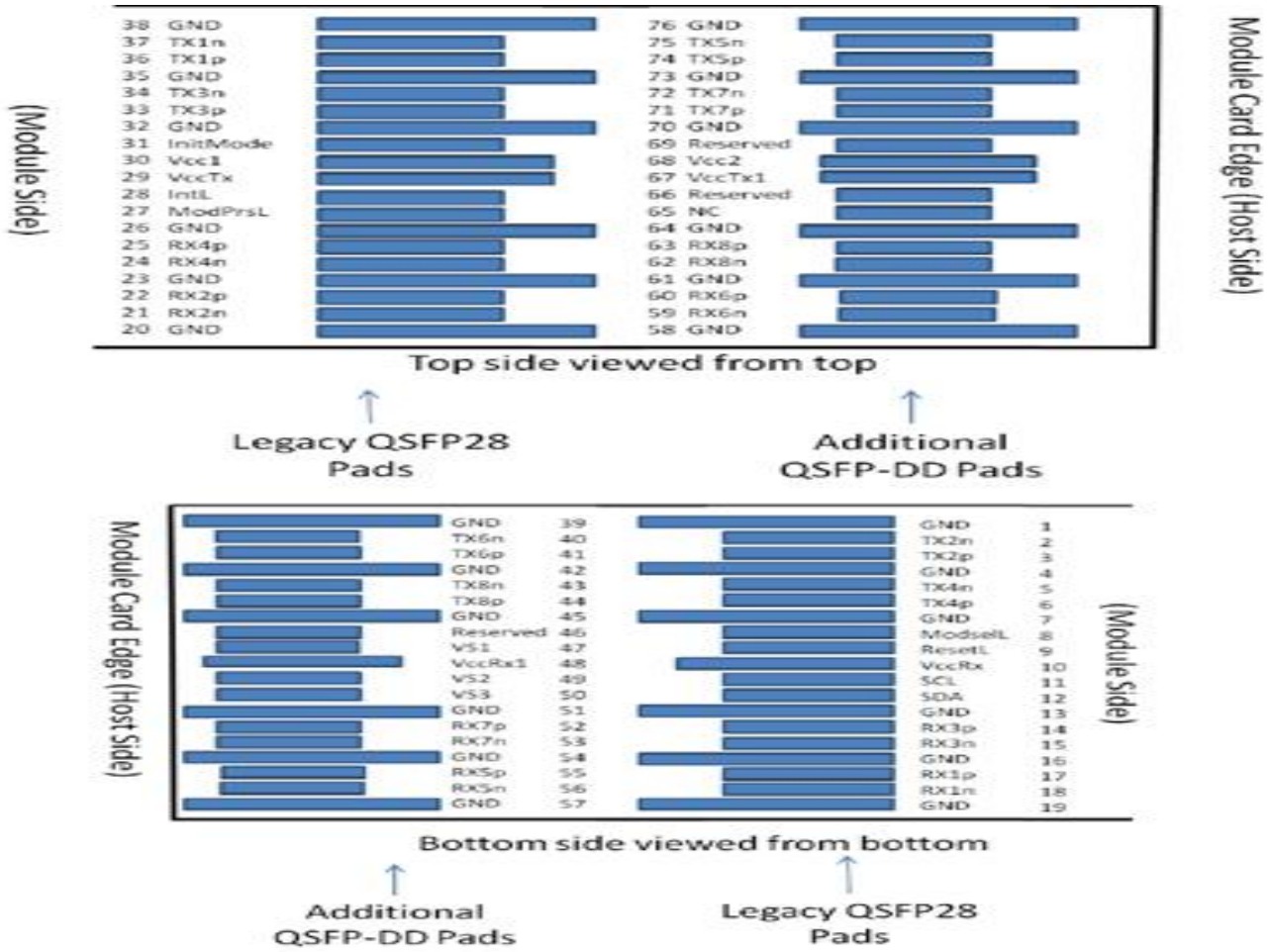

QSFP112 Electrical pinout

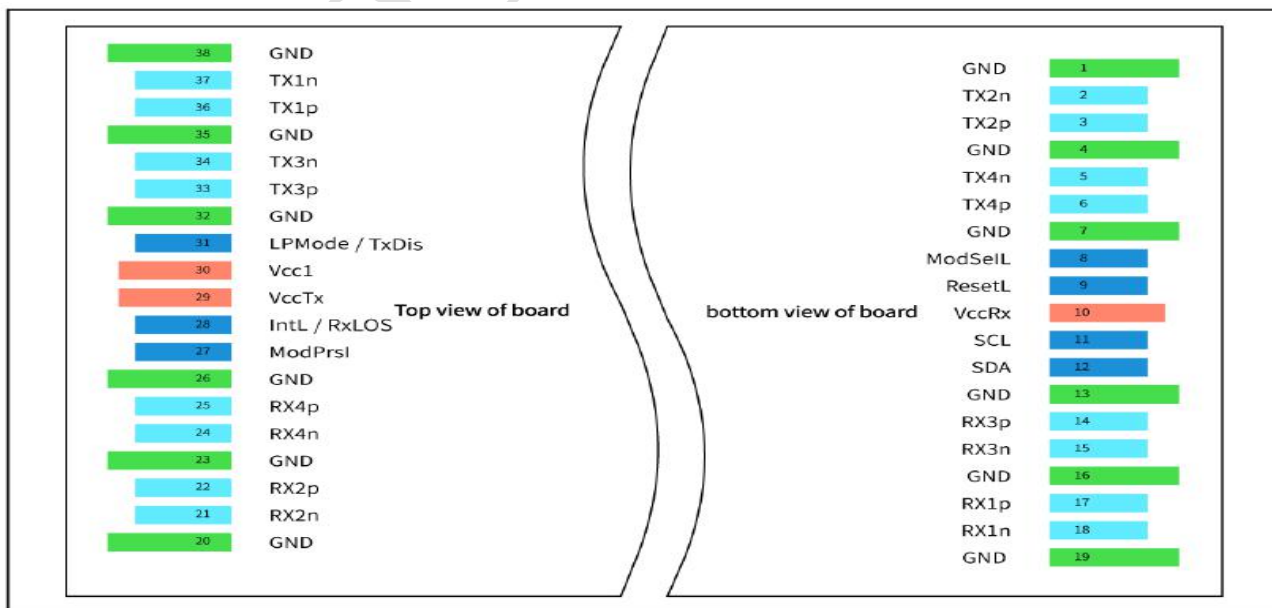

Wire connection diagram

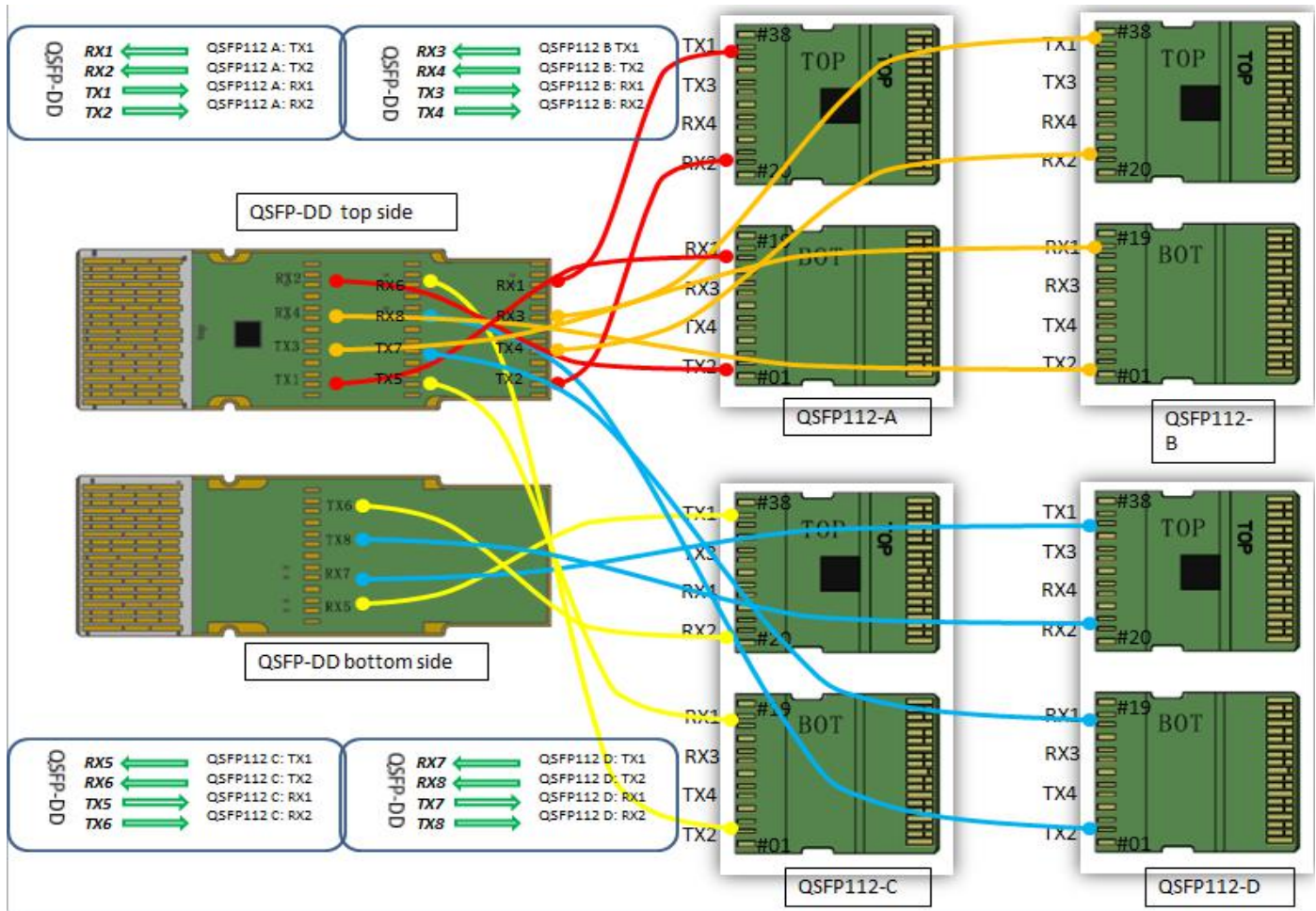

Ordering information

Part Number	GQD-4QSP801-XXC		
Length (meter)	0.5	1	1.8
Wire gauge (AWG)	30	30	26

If length(meter) is decimal, PN should be as GQD-4QSP801-DXXC.

Important Notice

Performance figures, data and any illustrative material provided in this data sheet are typical and must be specifically confirmed in writing by Gigalight before they become applicable to any particular order or contract. In accordance with the Gigalight policy of continuous improvement specifications may change without notice.

The publication of information in this data sheet does not imply freedom from patent or other protective rights of Gigalight or others. Further details are available from any Gigalight sales representative.

E-mail: sales@gigalight.com

Official Site: www.gigalight.com

Revision History

Revision	Date	Description
Preliminary	Mar-19-2025	Advance Release.